

# Tekno – Features & Benefits



# Gemini 2060 Chain

The Gemini 2060 Conveyor chain is specially engineered for non-synchronous pallet movement and tailored toward assembly operations. It features molded in place chain clips to prevent foreign articles from entering the chain or conveyor. The chain is designed to be 100% lubed for life for the factory, no additional lubrication or maintenance is required. The chain features nickel plated side plates and pins for extended life and corrosion resistance.

In Production since May 2014



# Gemini 2060 Built in Chain Cleaners

The Gemini 2060 Conveyor's drive assembly has a built in blower system to remove dirt and debris from the chain. These blowers come equipped in the drives and directed at the optimal point on the chain to remove the most dirt and debris. The blowers can be plumbed to a solenoid valve and programmed to routinely blow off the chain to prevent build-up.

In Production Since September 2015



# Gemini 2060 Quick Change Motors

The Gemini 2060 Conveyor's gearmotor has built in features that allow it to be quickly and easily changed. The gearmotor has a 1 5/16" hex bore in lieu of a traditional round shaft w/key. This make it much quicker and easier to slide a motor off and replace. Additionally there is a quick connect plug on each motor so there's no need to un-wire, just simply unscrew the old motor and screw in the new one.

In Production Since January 2004

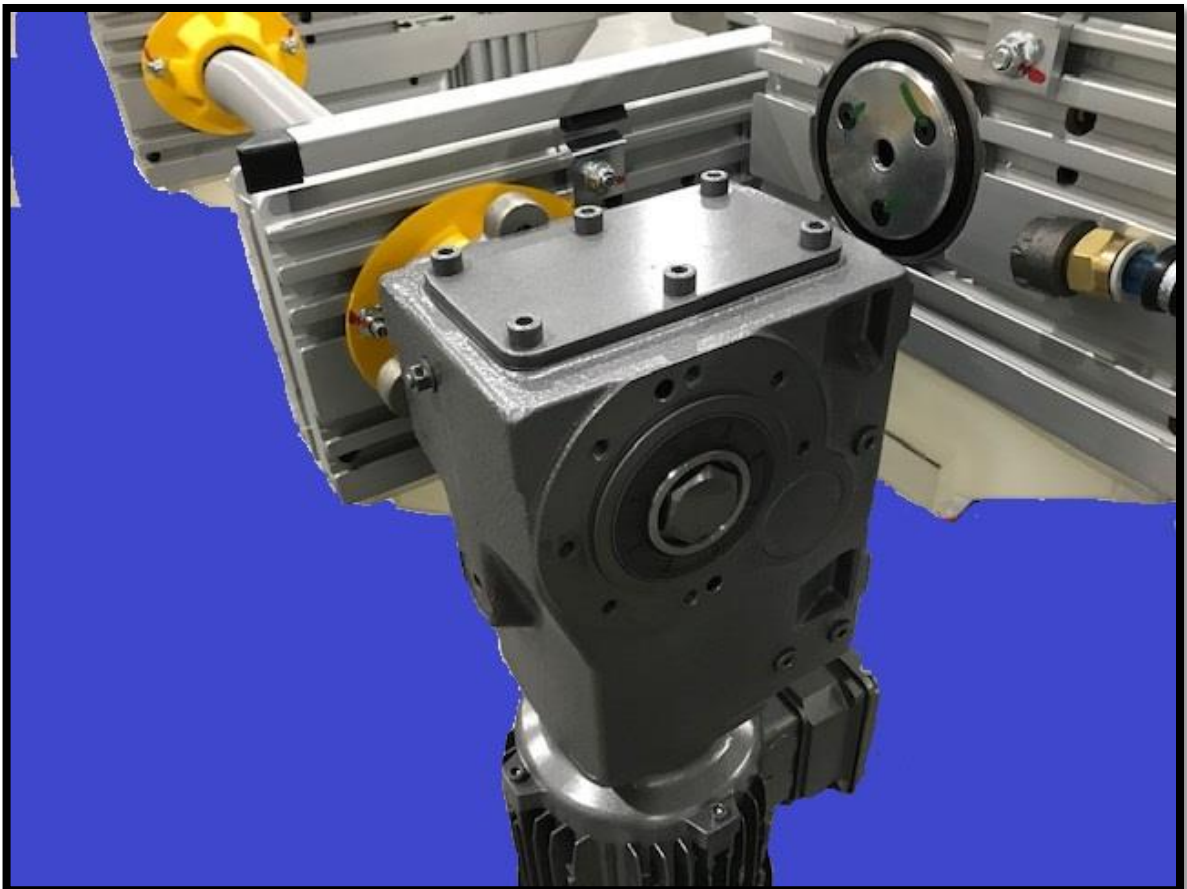

# Gemini 2060 Easy Clean Catenary Guards

The Gemini 2060 Conveyor used in an assembly operation will periodically build up dirt and debris from the assembly process and other outside influences. The items can be carried down the chain and deposited into the catenary guards at the end of the conveyor sections. These catenary guards have a hinged door that can easily be lifted to remove these articles without impacting production. Additionally they can be fitted with an attachment for a vacuum to aide in removal of the debris.

In Production Since May 2013





# Gemini 2060 Stoppers

The Gemini 2060 Conveyor system employs a variety of stoppers to control the pallet movement. These stoppers are completely guarded and protected from foreign articles.

In Production since April 2012

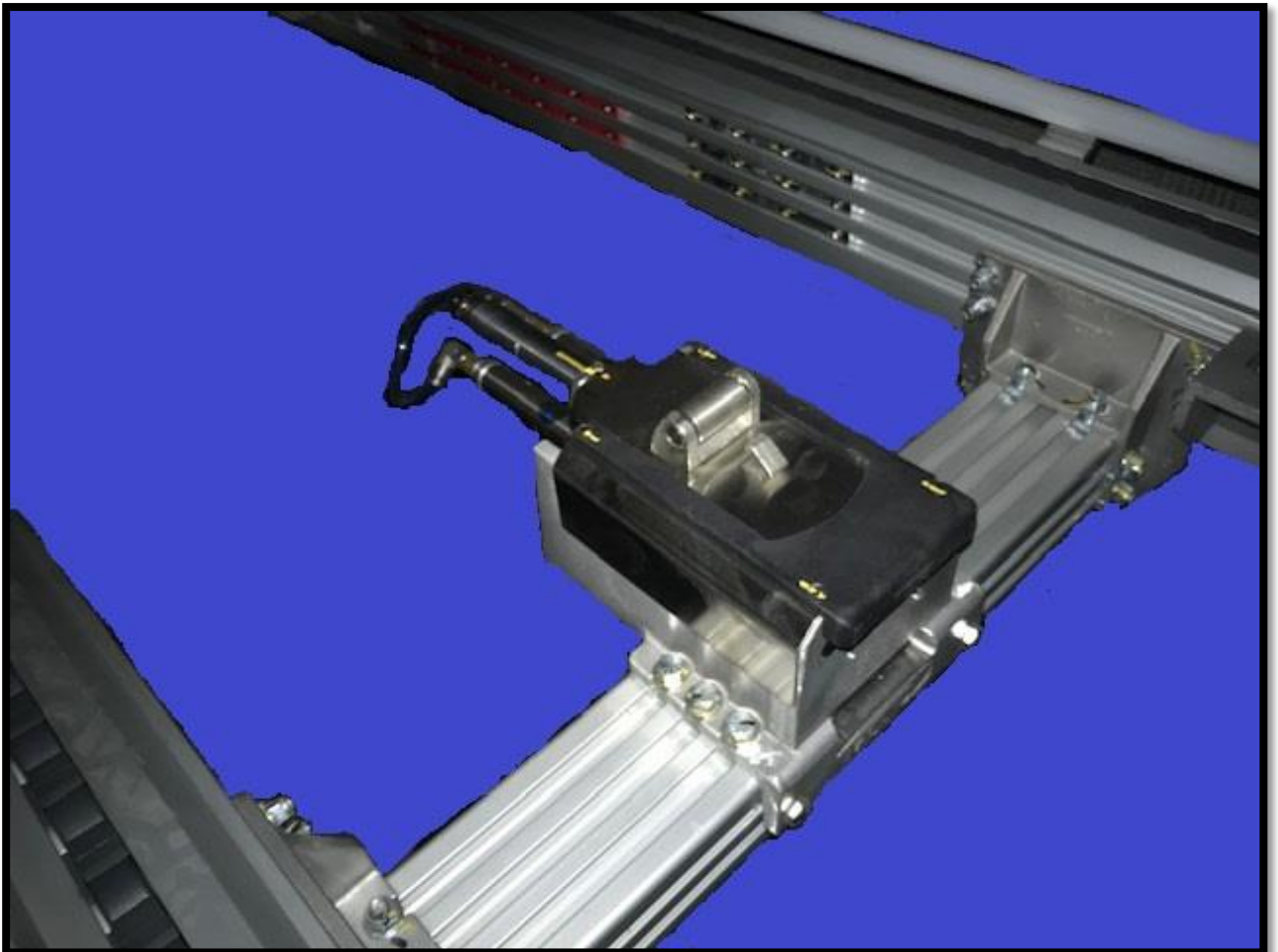

# Wire Management

The Gemini 2060 Conveyor system has a variety of wire management features and accessories to ensure the wiring is neat and tidy on all assembly lines. We use an aluminum wireway for device wires that run along the conveyor. We also have push-in nuts for wire tie anchors or small electrical devices. Additionally we offer T-slot cover to conceal single wires. All of these accessories are included and will be used on your conveyor system to ensure the wiring is neat and clean when the line is delivered to you.

In Production Since March 2017

